



K19-2000-0 XP1000 / Turbo S Front Bumper

Step 1 - Start at the front of the vehicle. Press the plastic tab at the top of the grille to remove the grille. Remove the lower plastic guard at the bottom front of the vehicle. Move the factory grille and plastic guard to a smooth flat surface.

For XP1k models

- Locate the mounting plate toward the bottom of the radiator

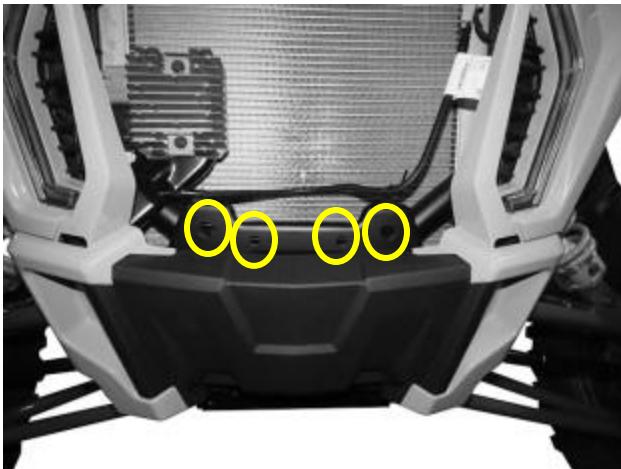

- From behind the mounting plate, inset (1) Bolt Plate into each of the (4) holes.
- Select the XP1K Mounting Bracket.
- Attach the Bracket to the (4) Bolt Plates with (4) 8mm Flat Washers, (4) 8mm Lock Washers and (4) 8mm Hex Nuts,. Do not tighten hardware.

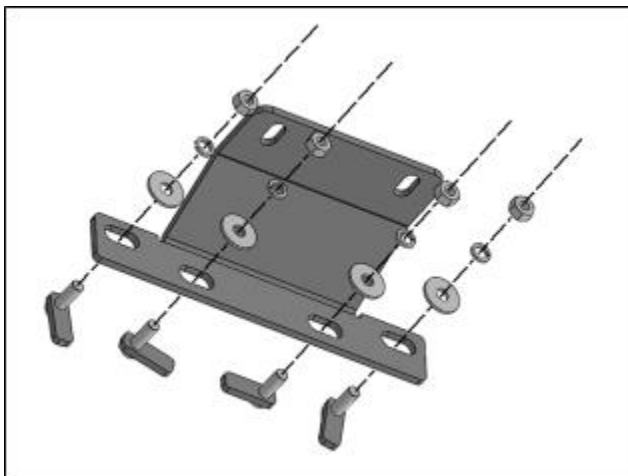

For Turbo S models

- Locate the crossbar toward the bottom of the radiator
 - From below the crossbar, insert (1) Bolt Plate into each of the 2nd to last holes in each side
- side

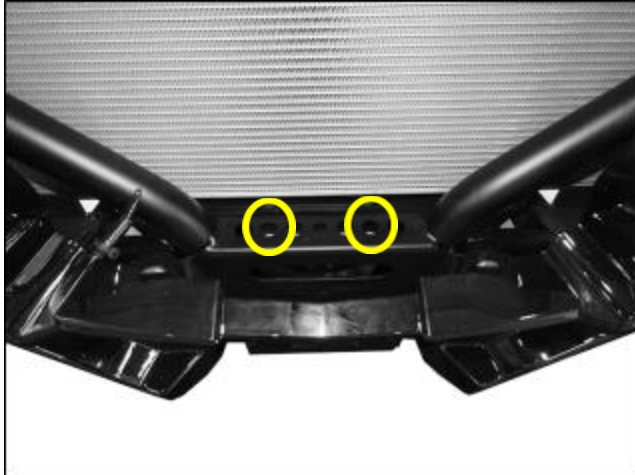

- Select the Turbo S mounting bracket.
- Attach the bracket to the (2) Bolt Plates with (2) 8mm Flat Washers, (2) 8mm Lock Washers and (2) 8mm Hex Nuts. Do not tighten hardware.

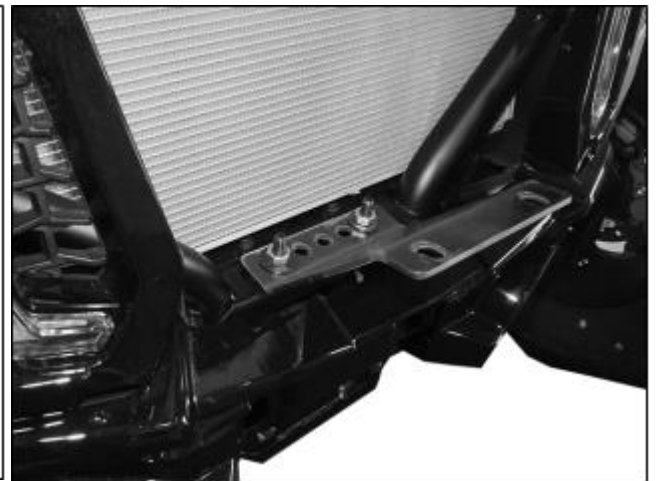
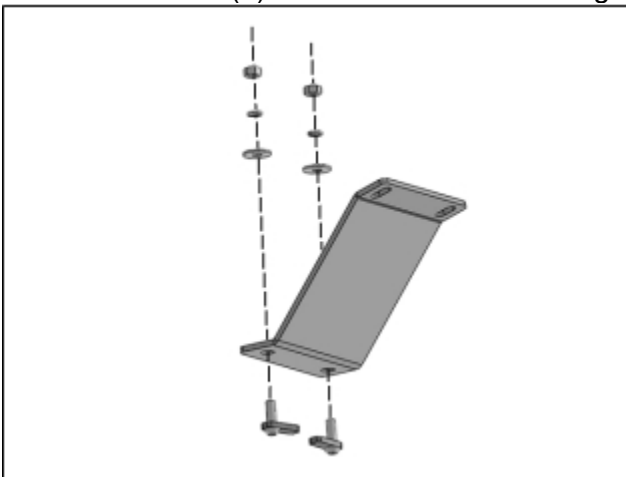

Step 2 -

- Reattach the factory grille to the vehicle.
- Select the Front Bumper. Attach the Bumper to the top of the Mounting Bracket with (2) 8mm Hex Bolts, (4) 8mm Flat Washers, (2) 8mm Lock Washers and (2) 8mm Hex Nuts. Do not tighten hardware.

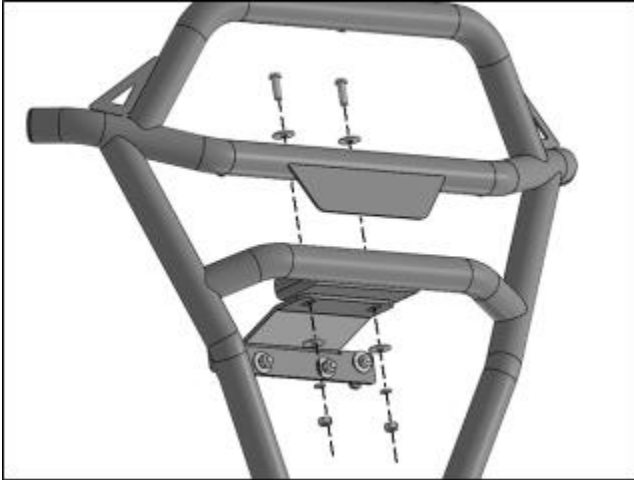

- From behind the lower mounting plate on the vehicle, insert the Spacer Plate and the Double Bolt Plate. Attach the bottom of the Bumper to the Double Nut Plate with (2) 10mm Hex Bolts, (2) 10mm Lock Washers and (2) 10mm Flat Washers. Do not tighten hardware. **Note:** for models equipped with a tow hook, attach the tow hook to the bottom of the bumper between the Flat Washers and the bottom of the Bumper.

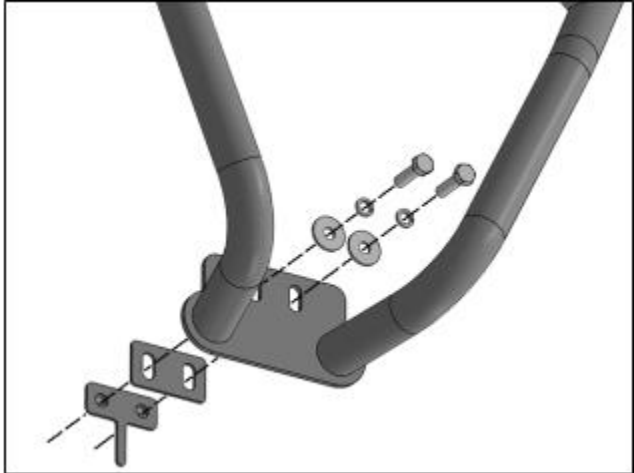

- Level and adjust the bumper and tighten all hardware.



Zbrozracing.com
customerservice@zbrozracing.com
435-753-7774